

**Donaldson® Cyclone Separators are designed for efficient removal of liquid water and particulate from compressed air and gases.**

Donaldson DF-C Cyclone Separators deliver high separation efficiency at low pressure drop through an optimal flow-path design. An innovative insert in the cyclone head creates centrifugal force that guides liquid and particulate to the housing wall. Friction with the housing causes the liquid and particulate to lose part of their kinetic energy and drop out of the higher moving airstream. Collected condensate is removed by a time controlled UF-2 condensate drain, while the purified compressed air or gas exits to the industrial application downstream.

Available in six different sizes with a flow range from 70 to 647 scfm at 100 psig. Conforms to European directive 97/23/EG for pressure vessels.



**DF-C Standard**  
with UF-2 time controlled  
condensate drain



**Flow Optimized Design**

FEATURES	BENEFITS
Flow-optimized design	Low pressure drop resulting in energy savings
Innovative spin insert	High efficiency over a broad flow range
Bayonet lock ensures housing cannot be opened under pressure	High safety during operation
Immersion-laquered housing on inside and outside surfaces	Long-term corrosion protection
Wall-bracket and UFM-D electronic level-controlled condensate drain options	Flexibility to meet installation and application requirements

## SPECIFICATIONS

MATERIALS		OPERATING CONDITIONS	
Filter Housing	Aluminum die cast	Design Pressure & Temperature	232 psi @ 150°F
Timer Drain	Brass	Test Pressure	332 psi
Housing Bowl Seal	Perbunan	Continuous Operating Temperature	34°F to 149°F

RETENTION RATE RELATED TO 116 PSIA		CLASSIFICATION PER 97/23/EG FOR FLUIDS GROUP 2	
≥ 5 micron	99%	DF-C 0120 to DF-C 0320	Art. 3, Par. 3
≥ 10 micron	100%	DF-C 0450 to DF-C 1100	Cat. 1

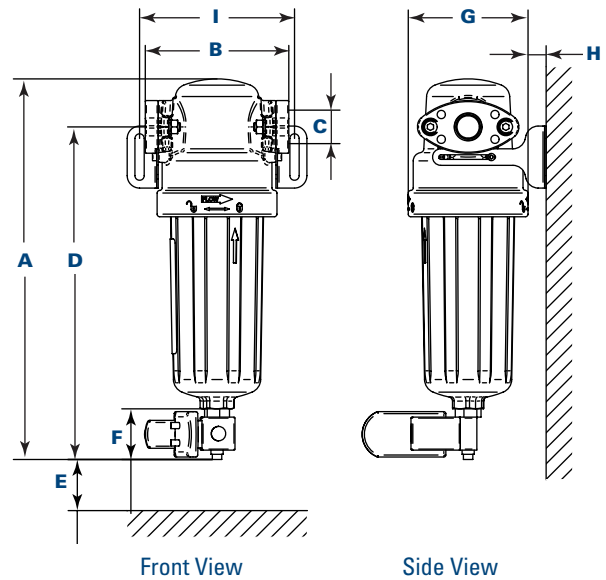
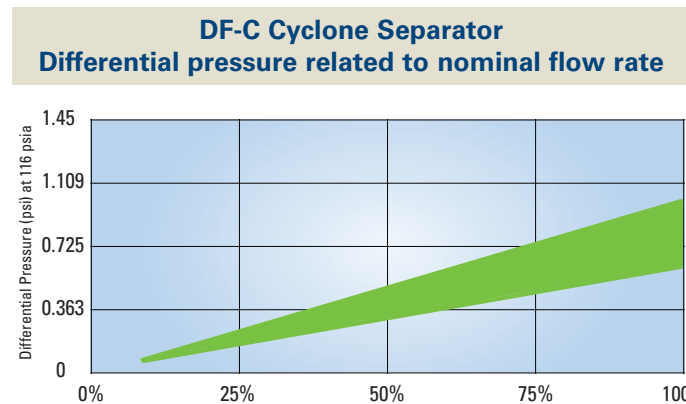

Size	Flow Rate* (scfm)	Volume (gal)	Weight (lbs)	Dimensions (inches)								
				A	B	C (FNPT)	D	E	F	øG	H (min/max)	I
0050	29	0.068										
0120	70	0.106	3.5	11.14	4.06	½	9.6	4.53	1.93	3.35	0.88 / 2	4.2
0210	123	0.304	5.9	14.51	5.5	¾	12.7	7.1	1.93	4.6	0.88 / 2.8	5.9
0320	188	0.304	5.9	14.51	5.5	1	12.7	7.1	1.93	4.6	0.88 / 2.8	5.9
0450	264	1.32	6.4	22.5	7.5	1½	20	9.8	1.93	6.3	0.88 / 13.56	7.5
0750	441	1.32	6.4	22.5	7.5	2	20	9.8	1.93	6.3	0.88 / 13.56	7.5
1100	647	1.32	6.4	22.5	7.5	2	20	9.8	1.93	6.3	0.88 / 13.56	7.5

\* Nominal flow at 100 psig, scfm related to 14.7 psia.



Donaldson Company, Inc.  
Compressed Air and Process Filtration  
PO Box 1299  
Minneapolis, MN  
55440-1299 U.S.A.

Tel 800-543-3634 (USA)  
Tel 800-343-3639 (within Mexico)  
Fax 952-885-4791  
compressedair@donaldson.com  
donaldsonprocessfilters.com

